

Total Station Autocollimator - E

UPGRADED

- An upgraded device based on our already mature technology for testing and adjusting fully integrated systems including mechanics, optics, and lasers.
- Emerging optomechanics AR/VR industry has introduced special applications requirement:
 - Interalignment and testing of lasers, optics, mechanics and electronic sensors
 - Angular accurate optical measurements with resolution of 0.01 arc sec or better.
 - Implementing fusion of several wavelengths including NIR into one system.
 - Measurements from remote mechanical dimensions.
 - Centering & Alignment
 - Measurements of multi laser array such as VCSEL in respect with other optical sensors
- Our Total Station Autocollimator does it all and much more, including projection of virtual objects from user defined distance.

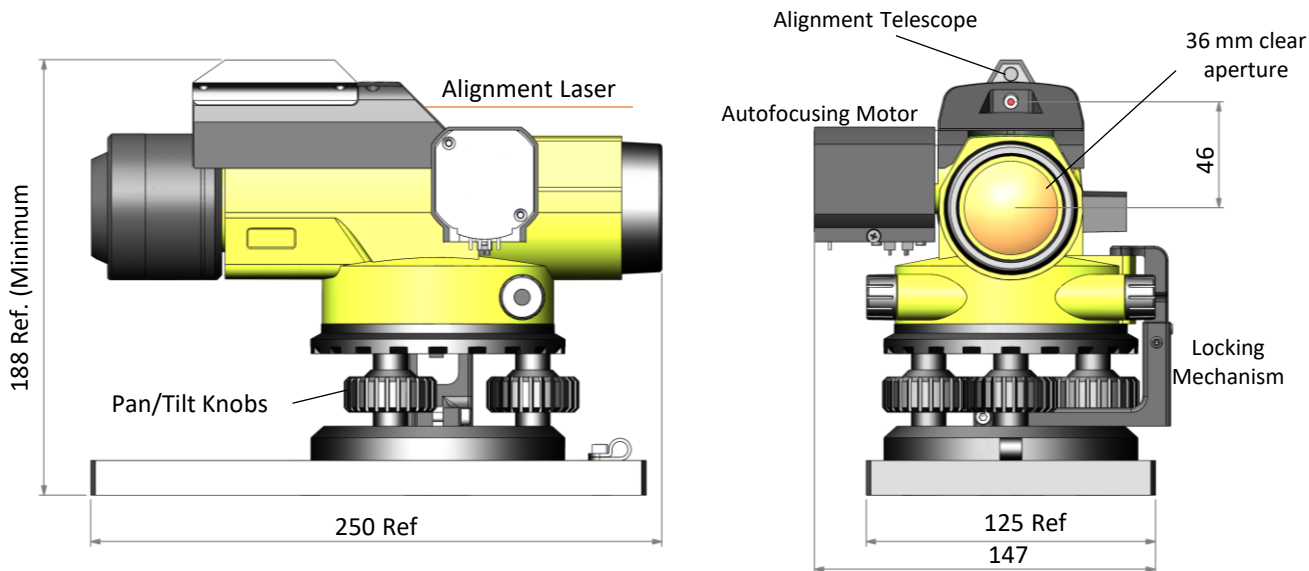

VCSEL Beam Profiler & Interalignment

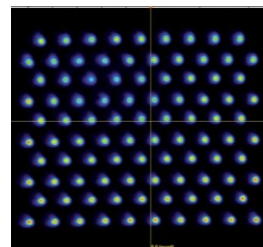

DUMA OPTRONICS LTD.

Total Station Autocollimator - E

UPGRADED

Specifications

Autocollimation	
FoV Autocollimator	±60' (H) x ± 40' (V)
FoV Beam Profiler	±120' (H) x ± 80' (V)
Clear Aperture	36 mm
Autocollimator's Resolution	0.005 sec
Autocollimator's Accuracy	1.0 sec
Light Source	-Switchable RG/IR -Switchable RGB -Special order: 1060 nm
Line of Sight Retention as Function of Focusing	±2.5 seconds
Focusing Distance	Calibrated from 18 cm to infinity
Built in coarse aiming Laser Pointer	650 nm power <1.0 mW Class 2 laser product, IEC60825-1
Spectral Response	350 – 1310 nm (Telescope Mode)
Resolution (H x V pixels)	8200 x 5600
Gain Control	x400
Exposure Speed	39 µsec to 2 sec
Frame Rate	50 fps, a few hundreds on ROI mode
Pixel Size	2.3 µm x 2.3 µm (binning 1)
Pixel Bit Depth	8/16 bits
Background Subtraction	User activated
Trigger	Internal Software
Interface	USB 3.0, Windows 8/10/11 (32 & 64 bit)

Beam Analysis – Collimated Laser Beams Input	
Max. Laser Beam Input Orientation	±100' (H) x ± 80' (V)
Laser Beam Divergence Measurement	Down to 0.05 mrad
Resolution of Beam Divergence	Better than ±5 µrad
Multiple Beams Measurement in Parallel	Standard – up to 400.
Parallel Multi-Beam divergence & power measurement (Default – 400 max.)	

General Measurements	
Straightness measurement – up to 2.5 meters	
Remote Lateral Mechanical Measurements – microns accuracy	
Testing of optical elements, including roll angle	
Image Projection & Focusing	
Target projection for optical systems from 2.5 meters to infinity	
Motorized Focusing from 0.18 meters to infinity	
Straightness Measurement	
Lateral Measurement on Object Plane	With micron accuracy dependent on object distance
Virtual Object Creation*	-2.5 [m] to -Infinity
Cooperative Cross Target	Automatic display of lateral deviation along -2.5 [m] to -Infinity

Ordering Information

EAC-1012-19-FO-E/T: Complete system including a collimator unit with USB3.0 camera, focusing mechanism, software on Flash Drive and a retro-reflector for infinity adjustment. See available models.

EAC-1012-19-FO-E/T-RG-IR: Autofocusing EAC, with Red, Green or IR – Switchable (default – Red IR 850 nm)

EAC-1012-19-FO-E/T-RGB: Autofocusing EAC, with Red, Green, Blue - Switchable

EAC-1012-19-FO-E/T-1060*: Autofocusing EAC, with LED 1060 nm

DUMA OPTRONICS LTD.

Website: <http://www.dumaoptronics.com>

E-mail: sales@duma.co.il

October 2023

