

M² Beam Analyzer HP – Knife Edge

M² laser beam propagation analyzer

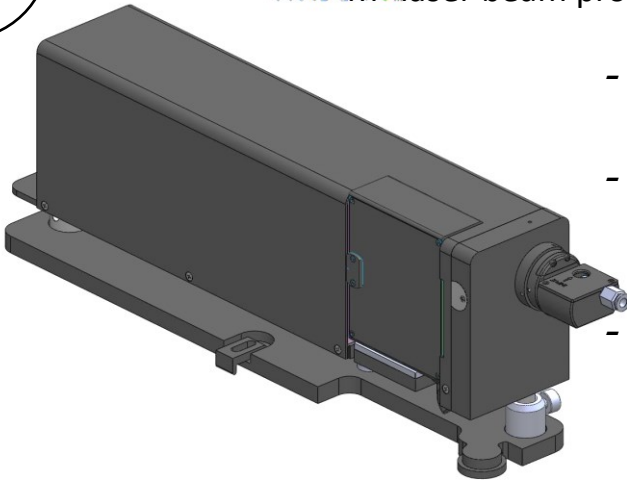

- Combines all ISO compliance accuracy
- Special version for high power measurements up to 4 kWatt
- Flexible, with removable measuring head for regular laser beam profiling
- Interchangeable filter drawers
- Adjustment center of rotation coincides with the center of input lens

Specifications

Input Beam

Technology	Double Reflection sampling head built-in with measuring instrument, USB system
Spectral Range (nm)	220 – 1550 with interchangeable measuring head Silicon head 350-1100
Beam Power Range	4 kW
Beam Size	8 mm, absolute maximum 10 mm
Minimum Detectable Divergence Angle	Better than 0.1 mRad
Accuracy	M ² Values & General Parameters Accuracy: ±5%
Typical Measurement Time	10 seconds, better if the system is allowed to cool off after two minutes
Cooling conditions	Filtered pressurized air of 6-8 Bar
Method	Main beam is sampled and directed towards knife-edge measurement head
Beam dumping	Supplied by user
Adjustment	Built-in pan/tilt

Scanning Assembly

Construction	Aluminium
Lens Focal Length	300 mm (at 632.6 nm)
Lens Diameter	25 mm
Number of Scan Steps	140
Minimum Step Size	100 µm
Scan Length	280 mm

Physical

Weight	2.5 Kg
Dimensions	85 x 160 x 530 mm
Mounting	M6 or ¼" screws
Mechanical Adjustment	Horizontal angle: ±1.5° Vertical angle: ±1.5°
Cable Length	2.5 m

DUMA OPTRONICS LTD.

Website: <http://www.dumaoptronics.com>

E-mail: sales@duma.co.il

May 2024



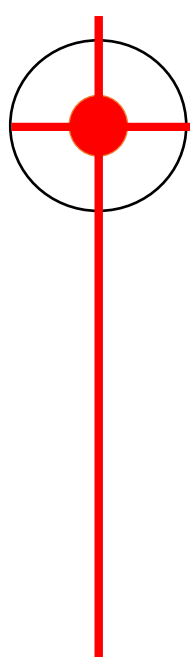

M2 Beam Analyzer HP – Knife Edge

M² laser beam propagation analyzer

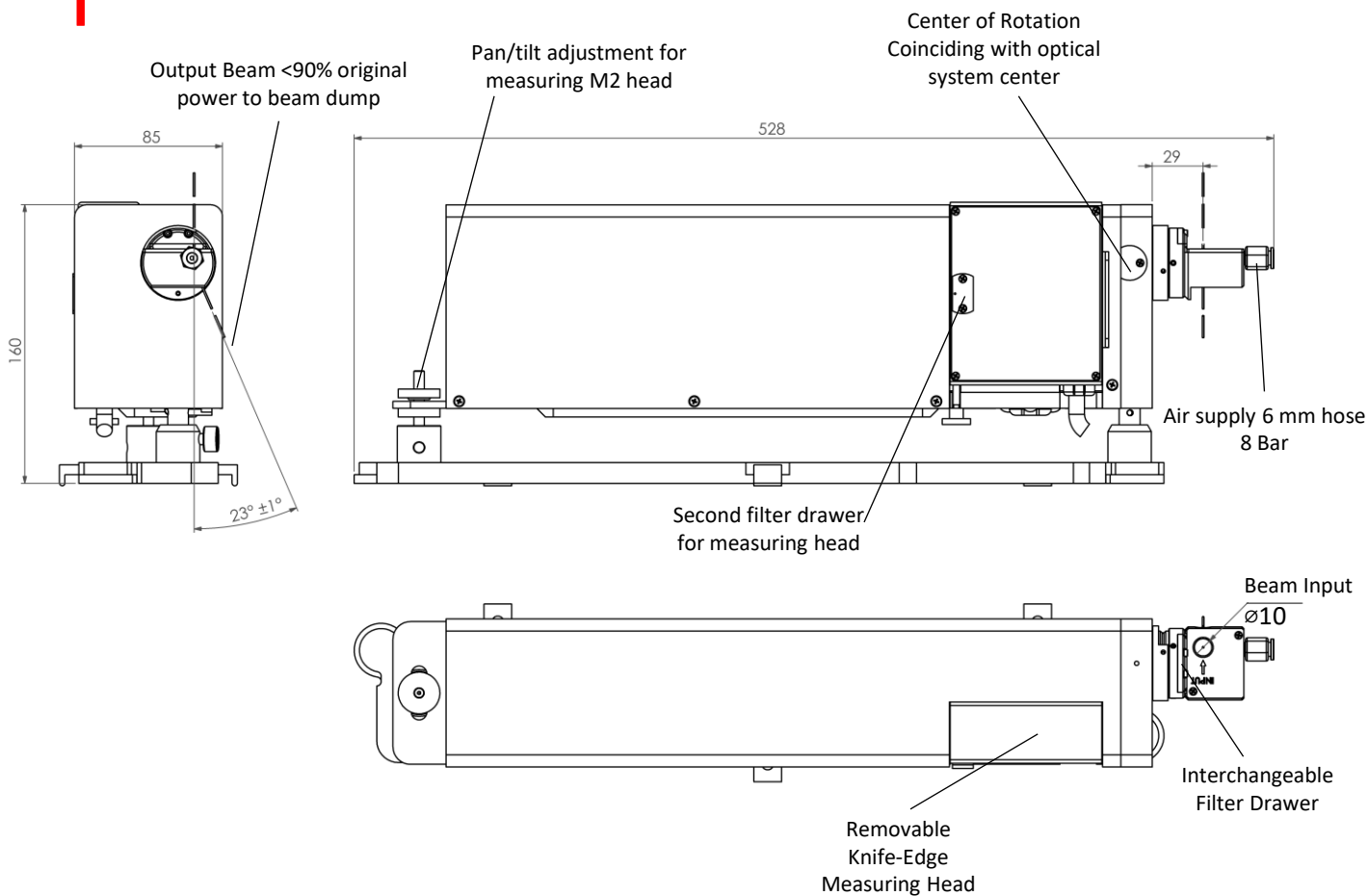

Ordering Information

M2Beam-Si-HP – measurement device for silicon range (350 – 1100nm)

M2Beam-UV-HP – measurement device for silicon range (190 – 1100nm)

M2Beam-IR-HP – InGaAs measurement device (800 – 1800nm)

*For IR possible sensors – InGaAs 3 mm dia., 5 mm dia., 10 mm dia.

DUMA OPTRONICS LTD.

Website: <http://www.dumaoptronics.com>

E-mail: sales@duma.co.il

May 2024

